

BeeWrap

> Machine dimensions Working set up

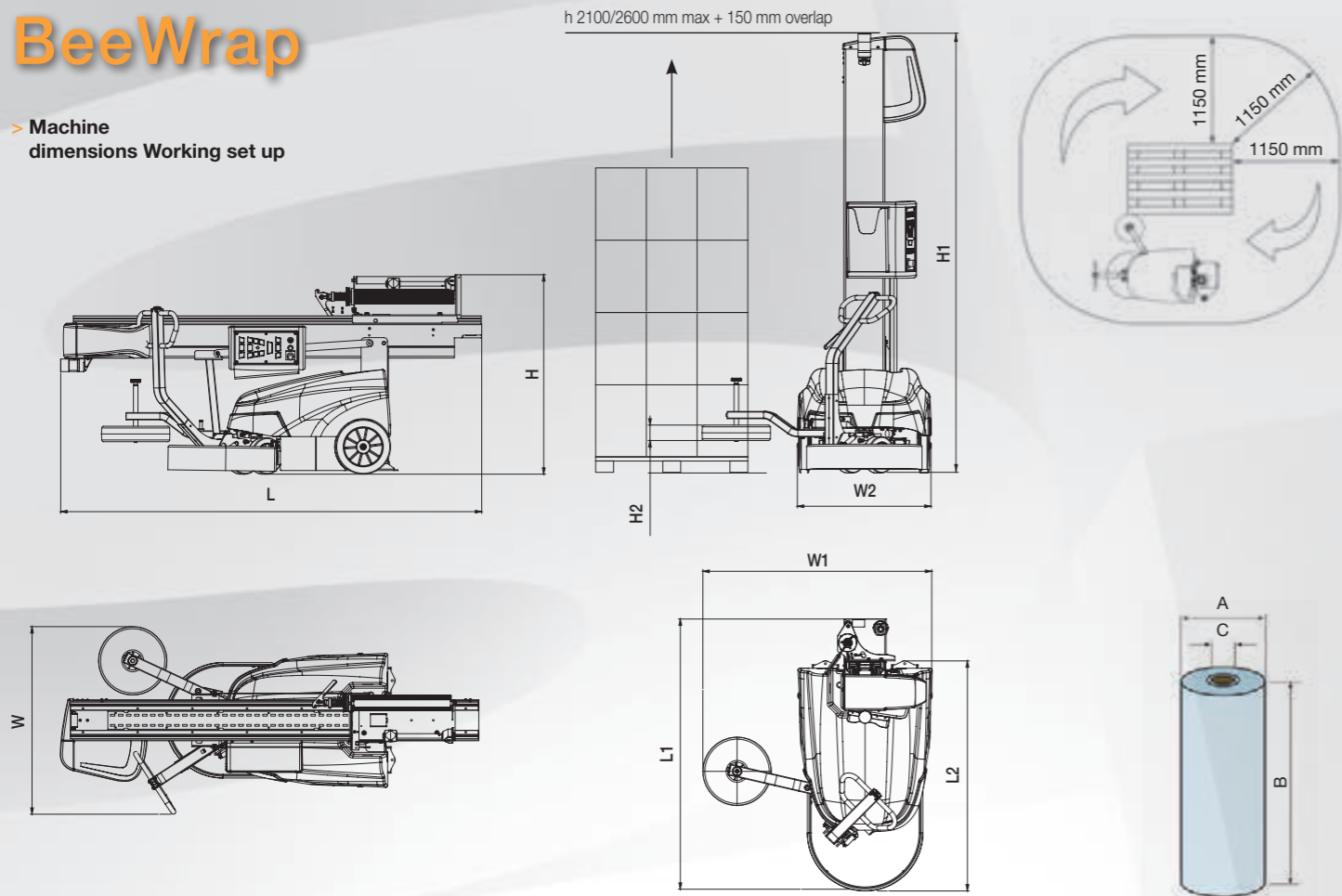

www.zen-arte.it

> Machine dimensions Reclined column	M/FM Carriages	LP Carriage
W (mm)	1027	1029
H (mm)	1094	1147
	2100/2600 Column	2100/2600 Column
L (mm)	2310 / 2810	2310 / 2810
Weight (kg)	316 / 355	335 / 380

> Shipping information	2100 Column	2600 Column
L (mm)	2290	2790
W (mm)	980	1000
H (mm)	1300	1300
Weight (kg)	393 / 432	412 / 457

> Machine dimensions / Working set up	M/FM Carriages 2100/2600 column	LP Carriage 2100/2600 column
H1 (mm)	2410/2910	2410/2910
H2 (mm)	65	65
W1 (mm)	1255	1255
W2 (mm)	733	733
L1 (mm)	1482	1547
L2 (mm)	1262	1262

> Film roll dimensions	
A (mm)	250
B (mm)	500
C (mm)	76
Thickness (µm)	17/23

> Technical features	
Nr. of pallets for single batteries charge	300*
Rotation speed (m/min.)	50min. / 80max
Up & Down carriage speed (m/min.)	1min. / 5max
Power supply (V)	100 Vac ÷ 240 Vac
Installed power (kW)	0,35 Kw
Lead acid batteries	2 x 12V 90 Ah (C5)
Gel batteries	2 x 12V 105 Ah (C5)

> Min./Max loading sizes	Min.	Max
L (mm)	500	***
W (mm)	400	***
H (mm)	600	2100/2600
Weight (Kg)	45**	∞

* Test conditions:
Standard Column 2100mm
Lead acid batteries
Pallet dimensions mm 800 x 1200 x 1500 (h),
up & down cycle, 2 top wraps & 2 bottom wraps, film tension 10daN.

** With film tension of 6daN applied.

*** Bulky load can be wrapped up to a total perimeter of 26 mt in standard configuration.



Cod. pubbl.:SBC0029544

SIAT

MAILLIS

BeeWrap Advanced Semi-Automatic Mobile Pallet Wrapper

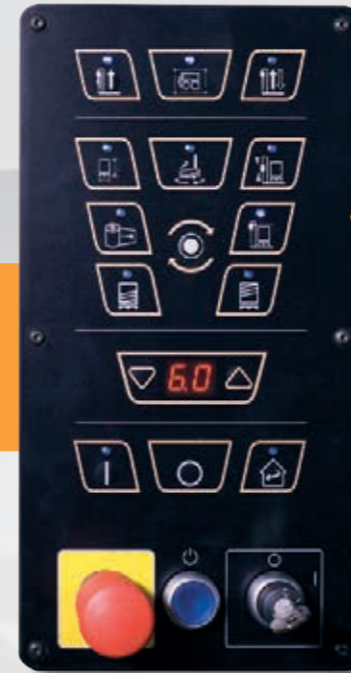

**NEW FEATURES!
ELECTRONIC BOARD
& CONTROL PANEL**



BeeWrap

BeeWrap is the Advanced Semi-Automatic Robot Wrapper.

BeeWrap is the mobile wrapping machine for palletized loads suitable for every shape, dimension and weight using stretch film. It is provided with a digital control panel that allows, in a very easy and functional way, the programs management and the wrapping parameters set-up.

Key Features

- For pallets of height up to 2100/2600 mm
- Suitable for large and round loads
- Free working space needed: 1150 mm
- Safety sensors on bumper
- Safety operation indicator light and beeper
- 2 x 12V lead acid battery with on-board battery charger
- Rudder for easy motorized robot moving
- Adjustable height tracing wheel
- Rear forklift access
- Reclining column for easy shipment and movement
- Advanced control panel: up to 10 recordable programs
- Film carriage with clutch (mechanical or electromagnetic) or powered prestretch (240%)
- Pallet height photocell
- Up to 300 pallets without recharging (* see technical data)

Options

- Gel batteries
- Photocell for black film or colored products
- Remote control
- Film cutting system (on LP carriage only)
- Double tracing wheel

NEW panel is divided in 4 main areas:

1 Section for mode of operation selection

2 Parameters setting for cycle characteristics

3 Display area with selection arrows

4 Section for start/stop/homing and power switch, ready and emergency stop



The new modern design of the control panel offers at a glance the complete control of the wrapping cycle parameters. Up to 10 recordable programs to avoid human mistakes and to save time. Control panel can be locked improving safety standards.

Operation indicator light and beeper for a safer work condition.



Customize your BeeWrap with the most suitable carriage for your loads!



M - Mechanical brake
FM - Electromagnetic brake
LP - Powered pre-stretch 240% (200% - kit available as option)



Remote control (option)



Double tracing wheel (option)

Adjustable height tracing wheel

View of reclined column



Flexibility: rudder for manual moving

Safety bumper

Pallet height photocell

Rear forklift access. Move it faster!

