

CG25 ST

Taping machine with manual regulation for gummed paper

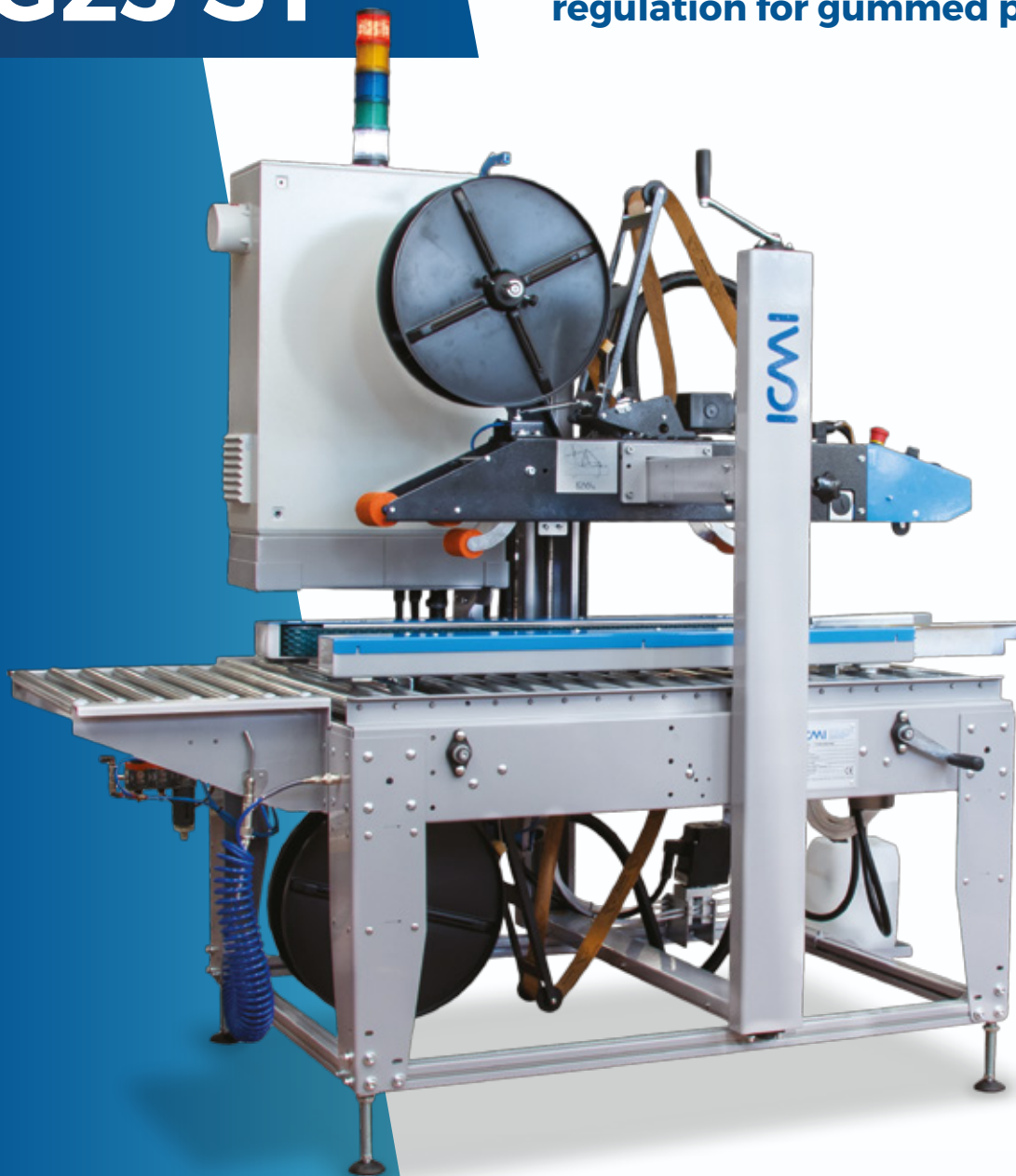

The wise, efficient and responsible solution for your packaging.

ICMI
WISE PACKAGING

CG25 ST is a Taping machine for gummed paper designed for taping a set of boxes of the same size. Adjusting to the box size is manual but simple and fast. The box is manually introduced after the upper flaps are folded (closed) by the operator. The machine automatically sticks on the gummed paper above and below, sealing the boxes.

www.icmi.it

24040 Bonate Sopra - Bergamo - Italia
Tel. +39 035 883 450 Fax +39 035 885 151 sales@icmi.it

Technical data

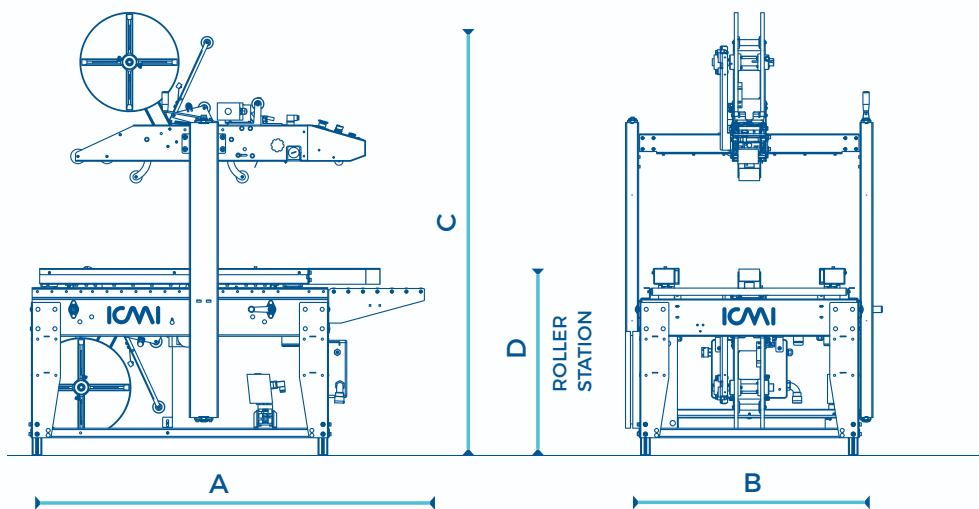

A	1640 mm
B	1065 mm
C	1830 ± 50 mm
D	690 ± 50 mm

(Taping machine size for boxes W 600 H 600)

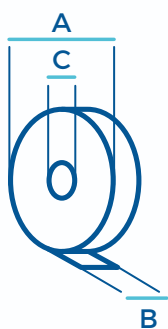

A	Max 400 mm
B	from 50 mm to 80 mm
C	70 mm



L	from 150 mm to ∞
W	from 140 mm to 600 mm
H	from 90 mm to 600 mm

Customizable dimensions on request

Average production



Max 12 boxes per minute*

*Box size and temperature can affect average production.

Power supply



400 V 50 Hz

Electrical protection



IP 54

Weight



250 Kg

NB: ICMI can fulfill requests that do not fit within the data sheet.

Box transfer speed



400 mm/second*

* adjustable by touch screen

Installed power



0,6 kW

Pressure recommended



6 bar

Air consumption

0,15 NI/cycle

Temperature of use



from 10°C to 40°C

Operating humidity



40% - 65%

Characteristics

- Manual regulation for boxes of different sizes;
- Manual insertion of the boxes with upper flaps closed. Box dragging, simultaneous and automatic lower and upper taping;
- Gummed paper adjustable humidification;
- Gummed paper non-return ratchet device;
- Lack of inertial forces when unwinding the paper tape from the reel thanks to the pivoting roller brake;
- Pneumatically controlled, self-sharpening guillotine cutting group; Rollers to press the gummed paper onto the boxes can be adjusted: pressure can be changed depending on the contents and/or thickness of the boxes;
- Front and behind can be changed from 60 to 80mm according to paper width;
- Peristaltic pump that sends and draws humidification water from the tank (5 liters) to the humidification units, sending the excess back into the tank. Constant humidification of gummed paper is guaranteed even on lines with discontinuous capacity;
- Humidification unit heating by cartridge heater, stainless steel, 100 W, 24 Vac, thermostat installed on the taping head and connected to the electrical panel. This is essential at temperatures below 18°C and/or medium/high output: it improves and speeds up the glue reaction of the gummed paper. The temperature can be adjusted by touch screen up to 60°/70° with sens. PT 100;
- None of the mechanisms need lubricating because they are fitted on self-lubricating brass bushes (excluding the transmission chains);
- Electrical control box made in compliance with EN-60204-1, in a box with IP55 protection level, containing the components at mains voltage and at 24V 50Hz;
- Possibility of changing the box insertion direction;
- Touch screen for operator data interchange.

Optional upon request

- External interface signal of the overflow;
- End-reel reader for upper and lower taping head;
- Upper and lower taping head control reader with counter device;
- Upper and lower taping head exclusion control;
- Data interchange package;
- Customized colour;
- Wheels with brake.

Structure

- Painted iron frame;
- Hand-wheel for adjusting the width and height of the machine to the size of the box;
- Sliding plane with idle rollers;
- Box conveying with side belts. All unpainted details are electro-galvanized;
- Painting: 7004.

Taping unit/head

Patented gummed paper dispensing and wetting units capable of using 85 g/m² to heavy reinforced papers without registration. Inspection activities are easy and smooth.

Taping Machine CG25 ST complies with machine directive 2006/42/CE and is always delivered with the conformity declaration and marked "CE".



ICMI

Industria Costruzioni Macchine Imballaggio

Via Milano, 29/33 - 24040 Bonate Sopra (Bergamo), Italy

Tel. +39 035 883 450

Fax 035 885 151

sales@icmi.it

www.icmi.it