

SK10

Semi Automatic Case Sealer



SEMI-AUTOMATIC CASE SEALER

100%
MADE in ITALY

SK10

The SK10 is a new semi-automatic case sealing machine designed and engineered by SIAT specifically for small/medium fixed sized boxes. SK10 is the ideal case sealing machine for a variety of industries like food and beverage, chemical, clothing, textiles, electronics, furniture, electronics and furniture.

SPECIFICATIONS

Max Production Capacity: 1200 boxes/hour

Case type: FEFCO 0201

Max case weight: 30Kg.

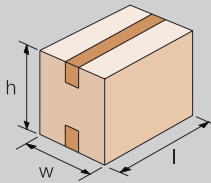

Box dimensions	L (mm)	W (mm)	H (mm)
MIN	150	140	90*
MAX	∞	500	500

*Box minimum height depends on tape leg height

KEY FEATURES

- » Seals upper & lower flaps of cardboard cases or cartons
- » Lockable electric isolation switch
- » Central emergency stop to work safety on both sides of the machine
- » Best-In-Class components with SIEMENS electrics
- » Top taping head removable
- » Quick release Taping Heads (Top & Bottom – No tools required)

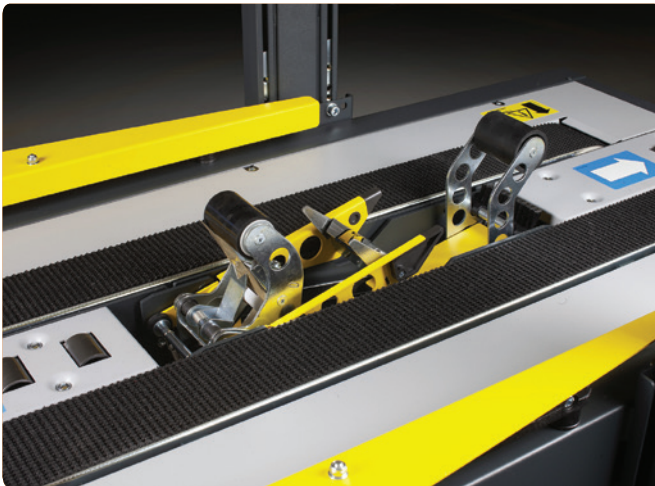

Possibility to order the version for K12 head for 75 mm tape width, in this case the minimum box width has to be 170 mm.



Fast Tape Head changeover - easy and toolless!

Aluminium Telescopic Legs, quick and easy to adjust.

Handle wheel

Top Sealing unit

Central emergency stop button

Bottom sealing unit

Lower conveyor

Centring device

Main switch

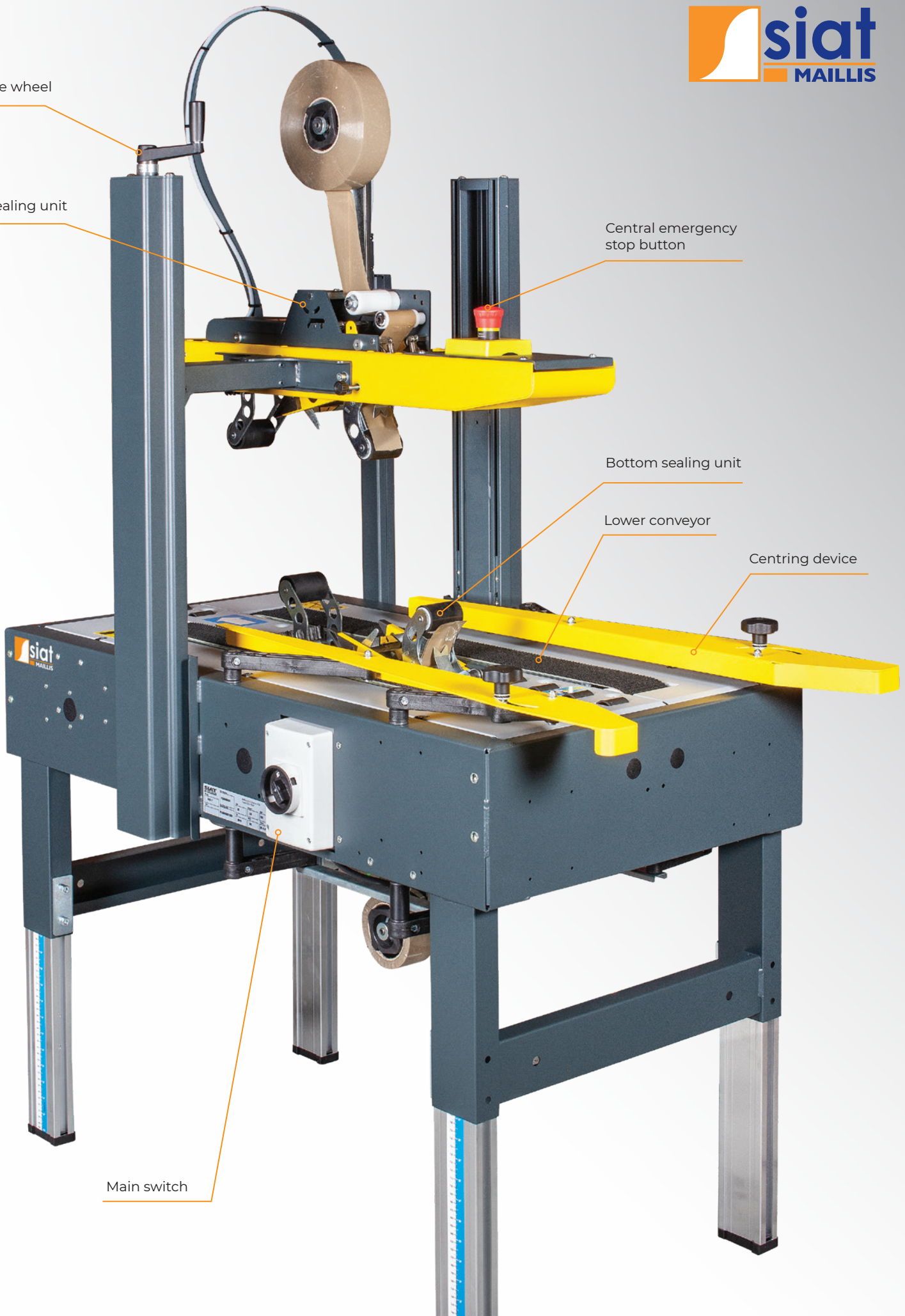

SK10

Machine dimensions

Dimensioni macchina
Maschinenabmessungen
Dimensions machine
Dimensiones de máquina

	Min (mm)	Max (mm)
Total H	1260	1600
H Bench	485	825
W	689	689
W Bench	572	572
L	1080	1080

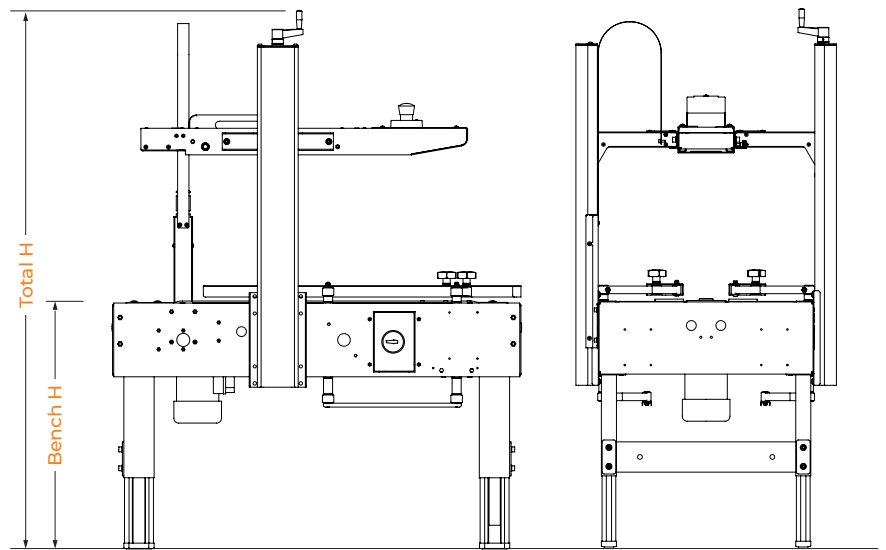

160



175



114(L) x 78(W) x 120(H) cm

Max Production capacity

Capacità di produzione
Produktionskapazität
Capacité de production
Capacidad de producción

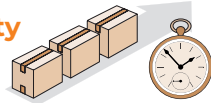

up to 1200 Bph

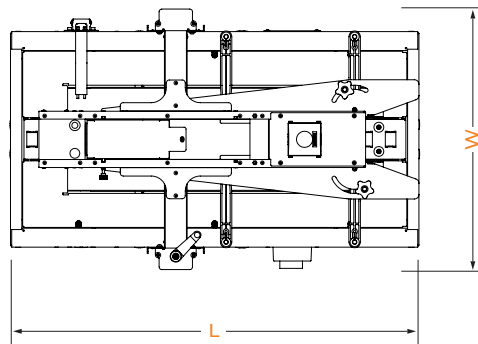

Standard power supply

Alimentazione standard
Standard-Stromanschluß
Alimentation électrique standard
Fuente de alimentación estándar

380/415V - 50Hz - 3ph	
440V - 60Hz - 3ph	
Amps	1,54
Power kW	0,13
Phase	3Ph + PE

Optional Extras

Accessori
Zubehör
Accessories
Accesorios

GTL - GTR

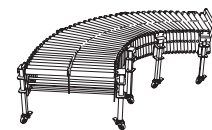

AS80

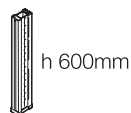

h 600mm

AS77

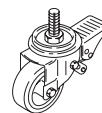

RG

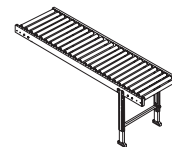

SIAT Spa

Via Puecher 22, 22078 Turate - Como
www.siat.com

100%
MADE in ITALY

SIAT AND MAILLIS GROUP

SIAT is the famous Italian Brand of strapping hand tools, semi-auto wrappers and case handling machines and proudly part of Maillis Group. Operating 5 production units around the

world and employing over 1,200 qualified staff, Maillis provides you with reliable system solutions incorporating machines, consumables and services to face your everyday challenges across different industries.

SIAT S.p.A is recognised worldwide as a top-class machine manufacturer for secondary packaging and produces more than 17,000 machines per year, and has done since 1970. Our product range includes semi-automatic as well as fully automatic machines like Case Sealers and Case Erectors, Stretch Wrappers, Strapping Tools / Machines, Flexographic Printing Machines and Tape Dispensers. The company is present in more than 100 countries and is constantly investing worldwide to meet customers actual and future demands.