



SIAT

M. J. MAILLIS GROUP

SR4 / SR46

Semi Automatic Carton Sealers



Descent limiting device

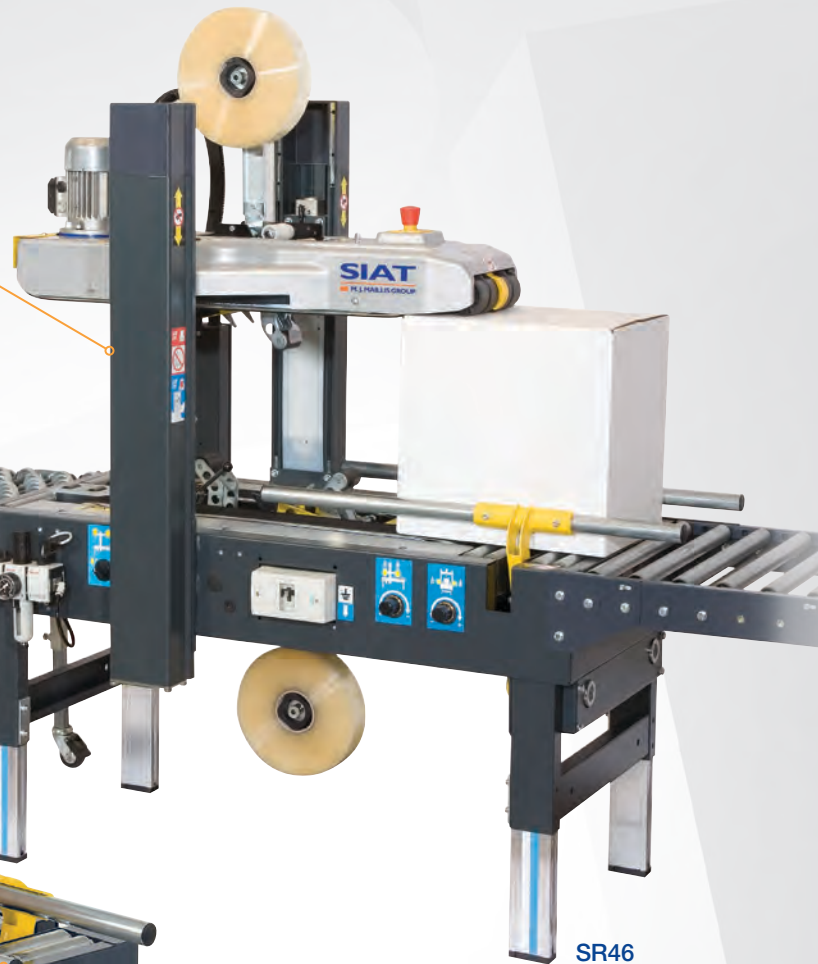

SR46



SR4

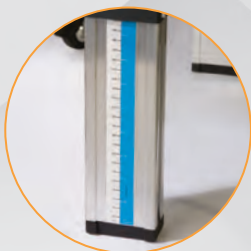

Aluminium telescopic legs



Pneumatic centering unit



for more details:



SR4

SR4 is a semi-automatic sealing machine with random adjustment. The machine consists of a metal structure painted with epossidic paint and columns in aluminium. The sliding plan of boxes is made up of galvanized rolls and stainless steel plate.

Working Cycle: the operator folds the top flaps and moves box forward in the machine until it is taken away by drive belts. The case sealer adjusts itself according to the box size and proceeds with the top and bottom sealing.

The machine has been designed in compliance with CE regulations.

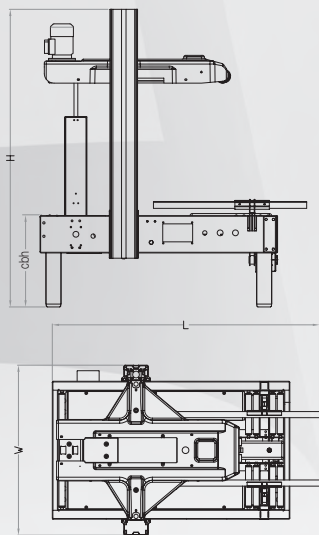

other languages: www.siat.com



> Machine dimensions

Dimensioni macchina
Machinemessungen
Dimensions machine
Dimensiones de máquina

Size / Weighth packaging			LxWxH
> SR4	145	185	130x78x115
> SR46	180	225	135x105x155

> SR4

	Min.	Max
L	1395	-
W	740	-
H	1180	1520
cbh	480	800
AS 77	580	900
AS 80	700	1100

> SR46

	Min.	Max
L	1395	-
W	890	-
H	1560	1900
cbh	480	800
AS 77	580	900
AS 80	700	1100

> Taping units

Unità nastranti
Verschliesseinheiten
Unités enrubanneuses
Unidades de precinto

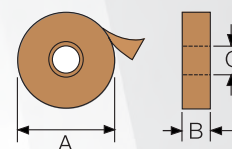

> Box dimensions

Dimensioni delle scatole
Kartonabmessungen
Dimensions des boîtes
Dimensiones de cajas

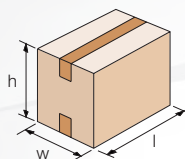

> SR4

	K11R std. / K12R on demand	
	Min.	Max
l	150	∞
w	140 / 170	500
h	100	500

> SR46

	K12R	
	Min.	Max
l	150	∞
w	170	650
h	100	650

	K11R/ K12R
	mm
A	410 Max
B	50 / 75
C	76

> Production capacity

Capacità di produzione
Produktionskapazität
Capacité de production
Capacidad de producción

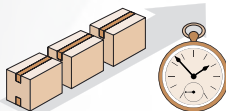

> SR4	Bph
Max pcs.*	900

> SR46	Bph
Max pcs.*	900

* Always based on shorter manageable box

> Air consumption

Consumo aria
Druckluftverbrauch
Consommation air comprimé
Consumo de arie

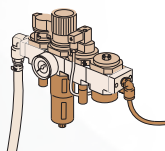

> SR4	NL.
Cycle	9

> SR46	NL.
Cycle	9

from 5,5 bar to 7 bar

> Standard voltage

Voltaggio standard
Standardspannung
Tension standard
Voltaje estándar

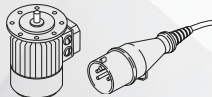

> SR4	
	380/400V - 50Hz - 3F
	440V - 60Hz - 3F
Amps	1,08
Power kW	0,26
Phase	3Ph + N + PE

> SR46	
	380/400V - 50Hz - 3F
	440V - 60Hz - 3F
Amps	1,08
Power kW	0,26
Phase	3Ph + N + PE

> Optionals

Accessori
Zubehör
Accessories
Accesorios

> AS80
Higher legs
Set gambe più alte
Höhere Stützen
Pieds plus hauts
Patas más altas

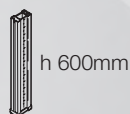

> AS77
Casters
Set ruote
Rädchen
Roulettes
Ruedas

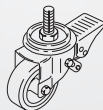

> RG
Roller conveyor
Piani a rulli
Rollenbahnen
Plans à rouleaux
Rodillos libres



> GTL - GTR
Extendable conveyor
Rulliera estensibile
Ausziehbare rollenbahnen
Convoyeur extensible
Rodillos extensibles

