

# Strapping Head

Robust & Reliable

## TP-703-SH TP-601D-SH

TP-703-SH and TP-601D-SH are the strapping heads to fulfill different requirements for tension, strap types, and strap widths, etc. Both TP-703-SH and TP-601D-SH are ideal for pallet strapping machines.

## TP-703-SH Medium-Duty Strapping Head

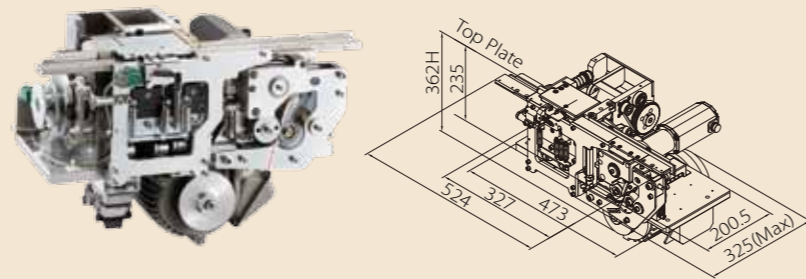

### Main Features

- Extremely reliable robust mechanism design and high engineering standard
- Friction-weld seal, no fumes and odours
- Tension level up to **300 kg** (medium-duty)
- Suitable for P.P. or PET straps, width from 9 mm to 15.5 mm
- Strap dispenser is on request

### Applications

- Automatic pallet strapping machine for horizontal applications (TP-703H)
- Automatic pallet strapping machine for vertical applications (TP-703VLM series)

## TP-601D-SH Light-Duty Strapping Head

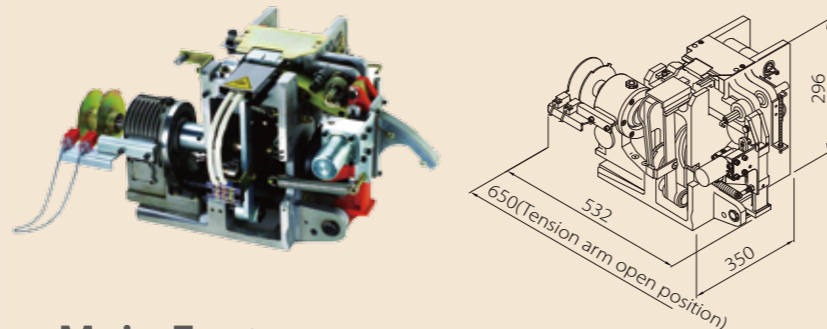

### Main Features

- Extremely reliable robust mechanism design and high engineering standard
- Heat seal
- Tension level up to **70 kg** (low tension)
- Suitable for P.P. straps, width 12 mm

## POLLUX TP-703VLM



Transpak pallet strapping machines secure pallet loads with plastic strapping. With the user friendly and state-of-the-art design, these machines provide excellent performance, easy operation, and low maintenance. In this category, we have four models as follows:

- Fully-auto pallet strapping machine for vertical applications Pollux TP-703VLM
- Fully-auto pallet strapping machine for horizontal applications Castor TP-703H
- Semi-auto pallet strapping machine for vertical applications Mini Verti TP-202MV
- Semi-auto pallet strapping machine for horizontal applications Mini Hori TP-202MH

# PALLET STRAPPING MACHINE



15F-1, NO. 17, SEC. 1, CHENGDE ROAD,  
TAIPEI 103, TAIWAN  
TEL: 886 2 2555 2515  
FAX: 886 2 2555 2516  
WEB: www.transpakcorp.com  
E-mail: transpak@transpak.com.tw

Made in Taiwan

07.2012x1000



All specifications are subject to change without notice.

## TP-703VLM

Pollux TP-703VLM is a fully automatic pallet strapping machine designed for packaging applications that require vertical strapping. It secures palletized package by vertical strapping with P.P. or PET straps. The TP-703VLM can accommodate a wide variety of products and be easily integrated with new or existing production lines. With the user friendly and state-of-the-art design, Pollux TP-703VLM provides excellent package performance, greater production efficiency and lower packaging cost.

### Main Features



#### TP-703-SH Strapping Head

TP-703-SH is an extremely reliable robust mechanism design and high engineering standard strapping head. It comes with a variety of features that make it simple to operate and easy to maintain.



#### Siemens PLC Control and HMI

The Siemens PLC control and HMI (touch panel) provide easy adjustments, operating instructions and troubleshooting guides. Easy TEACH-IN programming. User friendly.



#### Index Strapping Head

During the strapping cycle, the strapping head is movable towards the package with stroke of max. 500 mm. The strapping is done as close as possible to the package for maximum strap containment efficiency.



#### Modular Arch

Modular arch design for easy arch size change.



#### Movable Strap Lance

Feed the strap between the pallet void to strap palletized goods.

### Options

#### • Floating Head

Offer equalizing strap tension force around the package to increase the holding force.



#### • Top press

Offer adjustable compression pressure onto the pallet to compress the product and secure the stability of the pallet load.

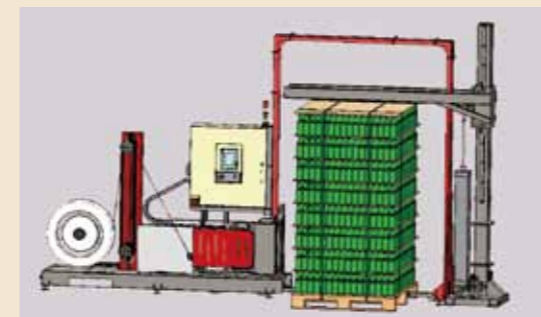

- Failure indicator
- Free standing operation desk
- HMI on the opposite side
- Strap Dispenser in transport direction
- Lower tension 200 – 1200 N (20 – 120 kg)

### More Features

#### Friction Weld Sealing Technology

Guarantee reliable joint and high sealing efficiency, tension up to 3000 N (300 kg). No fumes and odours.

#### Adjustable Sealing and Cooling Time

The sealing time and cooling time are adjustable. Guarantee high sealing efficiency.

### Arch Sizes

H \ W	1000	1400	2000
2050			
2450		Ⓢ	
2850			

Ⓢ Standard size: 1400 mm (W) x 2450 mm (H)

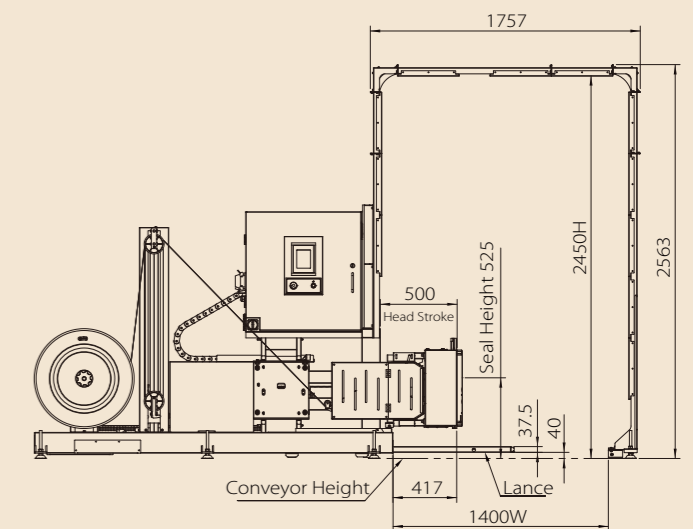

### Different Models Available

- TP-703V** closed strap track, fixed strapping head
- TP-703VL** with movable lance, fixed strapping head
- TP-703VM** closed strap track, index strapping head
- TP-703VLM** with movable lance, index strapping head

### TP-703VLM Technical Data

<b>Strap Type</b>	P.P. or PET straps
<b>Strap Width</b>	9 mm, 12 mm, 15.5 mm
<b>Strap Core Size</b>	406 mm
<b>Strap Tension</b>	1100-3000 N (standard) 200-1200 N (optional)
<b>Speed</b>	11 seconds per cycle (depends on package dimensions and arch size)
<b>Net Weight</b>	437 kg (standard size)
<b>Electrical Requirement</b>	220V, 380V, 400V 50/60Hz 3PH

Fully-Auto Pallet Strapping Machine for Horizontal Strapping Applications

## TP-703H

Castor TP-703H is a fully automatic pallet strapping machine designed for packaging applications that require horizontal strapping. It secures pallet loads and stacked boxes by horizontal strapping with P.P. or PET straps. The TP-703H can accommodate a wide variety of products and be easily integrated with new or existing production lines. With the user friendly and state-of-the-art design, Castor TP-703H helps maximize uptime for greater production efficiency and lower packaging cost.

### Main Features



#### TP-703-SH Strapping Head

TP-703-SH is extremely reliable robust mechanism design and high engineering standard strapping head. It comes with a variety of features that make it simple to operate and easy to maintain.



#### Siemens PLC Control and HMI

The Siemens PLC control and HMI (touch panel) provide easy adjustments, operating instructions and troubleshooting guides. Easy TEACH-IN programming. User friendly.

It has 10 strapping patterns with up to 10 different strapping positions. There is no need to adjust the setting when changing to different package sizes. Reduce downtime and save cost.



#### Index Strapping Head

During the strapping cycle, the strapping head is movable towards the package with stroke of max. 400 mm. The strapping is done as close as possible to the package for maximum strap containment efficiency.



#### Strap Guide Arm

To ensure precise strap positioning to the load.



#### Safety Rack

Underneath the arch to ensure the highest safety.



#### Reinforced dual-track-pillar system

Robust construction provides the highest reliability and ensures the highest safety to the frequently moved strapping head.



#### Variety Applications

TP-703H can accommodate a wide variety of products like bricks, fruits, cans, bottles, beverage, and all kinds of palletized goods.

### More Features

#### Friction Weld Sealing Technology

Guarantee reliable joint and high sealing efficiency, tension up to 3000 N (300 kg). No fumes and odours.

#### Adjustable Sealing and Cooling Time

The sealing time and cooling time are adjustable. Guarantee high sealing efficiency.

#### Stable Arch Movement

Vertical arch movement with inverter to avoid vibrations.

### Options

- Free standing operation desk
- Failure indicator
- HMI on the opposite side
- Lower tension 200- 1200 N (20- 120 kg)

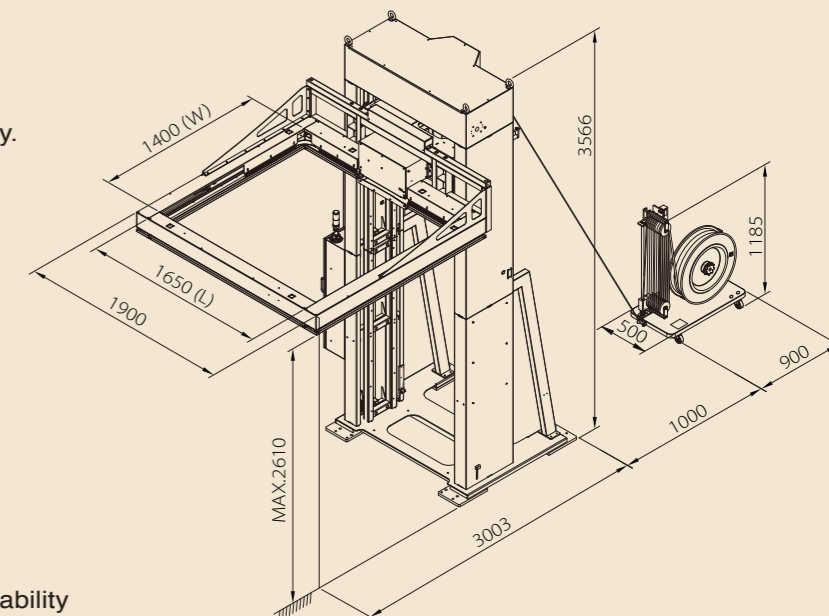

### TP-703H Technical Data

<b>Strap Type</b>	P.P. or PET straps
<b>Strap Width</b>	9 mm, 12 mm, 15.5 mm
<b>Strap Core Size</b>	406 mm (200/280 mm optional)
<b>Strap Tension</b>	1100-3000 N (standard) 200-1200 N (optional)
<b>Speed</b>	8.5 seconds per cycle (depends on package dimensions)
<b>Minimum strapping height</b>	60 mm above conveyor surface (depends on the package position), 185 mm above the floor
<b>Net Weight</b>	1145 kg
<b>Electrical Requirement</b>	220V, 380V, 400V 50/60Hz 3PH



# Mini Hori

Semi-Auto Pallet Strapping Machine for Horizontal Applications

## TP-202MH

The Mini-Hori TP-202MH mobile pallet strapping machine is suitable for fruit & vegetable boxes, concrete blocks, and pallets loaded with cardboard boxes containing any type of products. It can be moved easily beside the load you want to strap, no need to move the stacked pallet. The TP-202MH is a quick, ergonomic and economic solution for low volume horizontal pallet strapping.



## Main Features

- **Various Applications**  
Suitable for fruit & vegetable boxes, concrete blocks, and pallet loaded with cardboard boxes.
- **Adjustable Strapping Height**  
The strapping height is quickly and effortlessly adjustable. Allow to strap with height of 190 mm from the floor up to 2000 mm.
- **Control Panel on Both Sides**  
With the control panel on both sides of the machine, it is easy for operation.
- **Easy to Change the Coil**  
The position of strap dispenser is ergonomic design. It's convenient and energy-saving to change the coil of P.P. strap.
- **Weld-Cooling Timer**  
The weld cooling time can be increased to insure high joint efficiency under high tension.
- **Mobility**  
With big wheels for high mobility, it is easy to move the machine around.

## Option

- Battery power supply (TP-202MHB)

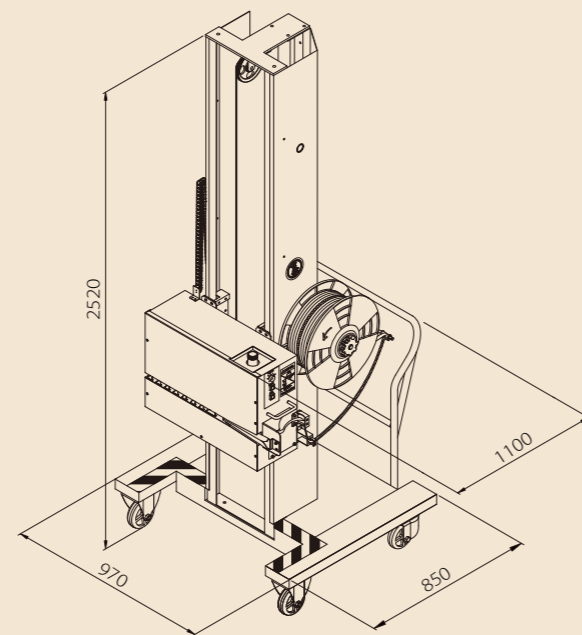

## TP-202MH Technical Data

<b>Strap Type</b>	P.P. strap
<b>Strap Width</b>	9 mm-15.5 mm
<b>Strap Tension</b>	15 kg-55 kg
<b>Net Weight</b>	260 kg
<b>Electrical Requirement</b>	110V, 220V, 230V 50/60Hz 1PH

## Main Features

- **Mobility**  
With light weight and compact size, it is easy to move the machine beside the pallet you want to strap.
- **Good for Lower Height Pallet**  
Enable to strap pallet with height as low as 280 mm
- **Easy Strap Feeding**  
Handle with feeding switch, convenient for users to feed the strap to the required length. User friendly.
- **Weld-Cooling Timer**  
The weld cooling time can be increased to insure high joint efficiency under high tension.
- **Various Applications**  
Suitable for corrugated cardboards, concrete blocks, and pallet loaded with cardboard boxes containing any type of products.

## Option

- Battery power supply (TP-202MVB)

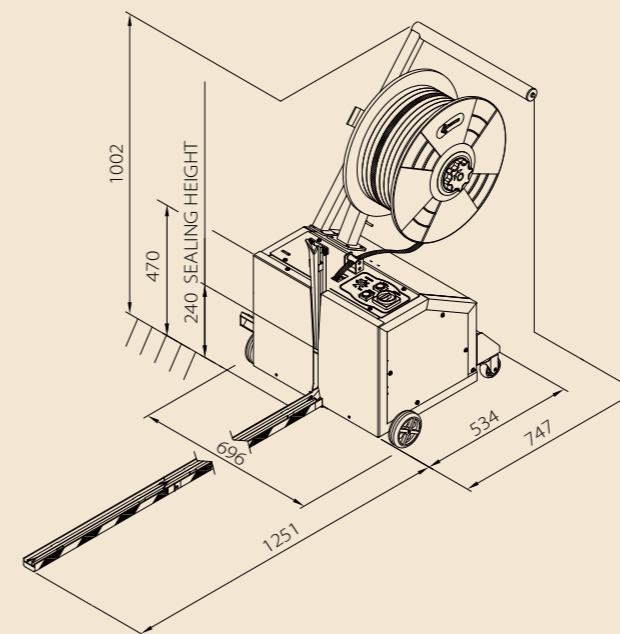

## TP-202MV Technical Data

<b>Strap Type</b>	P.P. strap
<b>Strap Width</b>	9 mm-15.5 mm
<b>Strap Tension</b>	15 kg-55 kg
<b>Net Weight</b>	90 kg
<b>Electrical Requirement</b>	110V, 220V, 230V 50/60Hz 1PH

# Mini Verti

Semi-Auto Pallet Strapping Machine for Vertical Applications

## TP-202MV

The Mini-Verti TP-202MV mobile pallet strapping machine eliminates the use of manual tools and dispenser. It can be easily moved beside the load you want to strap, no need to move the stacked pallet. The TP-202MV provides ergonomic and cost-effective solutions for low volume vertical pallet strapping applications.

