

Castor II

Fully-Auto Pallet Strapping Machine for Horizontal Strapping Applications

TP-713H

Castor II TP-713H is a fully automatic pallet strapping machine designed for packaging applications that require horizontal strapping. It secures pallet loads and stacked boxes by horizontal strapping with P.P. or PET straps. The TP-713H can accommodate a wide variety of products and be easily integrated with new or existing production lines. With the user friendly and state-of-the-art design, Castor II TP-713H helps maximize uptime for greater production efficiency and lower packaging cost.



Main Features



TP-703-SH Strapping Head

The TP-703-SH is a high engineering standard strapping head. It has extremely reliable robust mechanism design and comes with a variety of features that make it simple to operate and easy to maintain.



PLC Control and HMI

The PLC control and HMI (touch panel) provide easy adjustments, operating instructions and troubleshooting guides. Easy TEACH-IN programming. User friendly.

It has 10 strapping patterns with up to 10 different strapping positions. There is no need to adjust the setting when changing to different package sizes. Reduce downtime and save cost.



Index Strapping Head

During the strapping cycle, the strapping head is movable towards the package with stroke of max. 300 mm for maximum strap containment efficiency.

More Features

Friction Weld Sealing Technology

Guarantee reliable joint and high sealing efficiency, tension up to 3000 N (300 kg). No fumes and odours.

Adjustable Sealing and Cooling Time

The sealing time and cooling time are adjustable. Guarantee high sealing efficiency.

Stable Arch Movement

Vertical arch movement with inverter to avoid vibrations.

Reinforced dual-track-pillar system

Robust construction provides the highest reliability and ensures the highest safety to the frequently moved strapping head.

Variety Applications

TP-713H can accommodate a wide variety of products like bricks, fruits, cans, bottles, beverage, and all kinds of palletized goods.



Strap Guide Arm

To ensure precise strap position to the load.



Safety Rack

Underneath the arch to ensure the highest safety.

Options

• Floating Head

Offer equalizing strap tension force around the package to increase the holding force.



- Free standing operation desk
- Failure indicator
- HMI on the opposite side
- Lower tension 200- 1200 N (20- 120 kg)

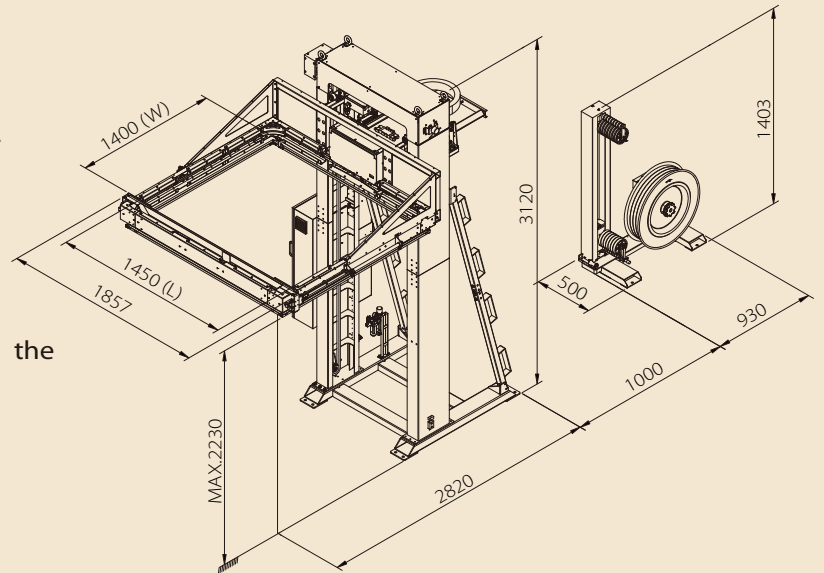
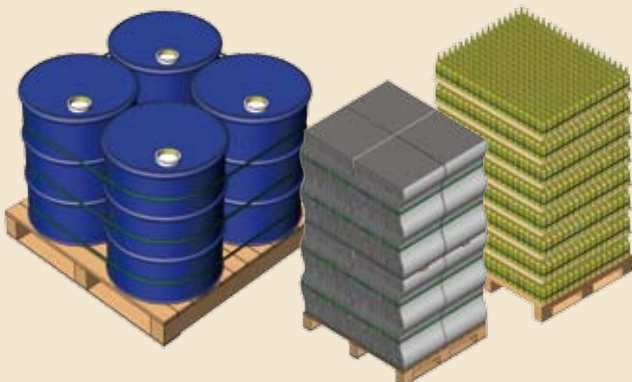

TP-713H Technical Data

Strap Type P.P. or PET straps

Strap Width 9 mm, 12 mm, 15.5 mm

Strap Core Size 406 mm

Strap Tension 1100-3000 N (standard)
200-1200 N (optional)

Speed Up to 60 pallets/hour (3 straps/pallet)
(depends on package dimensions)

Minimum strapping height

60 mm above conveyor surface (depends on the package position), 190 mm above the floor

Net Weight 875 kg

Electrical Requirement

220V, 380V, 400V 50/60Hz 3PH